

MTR

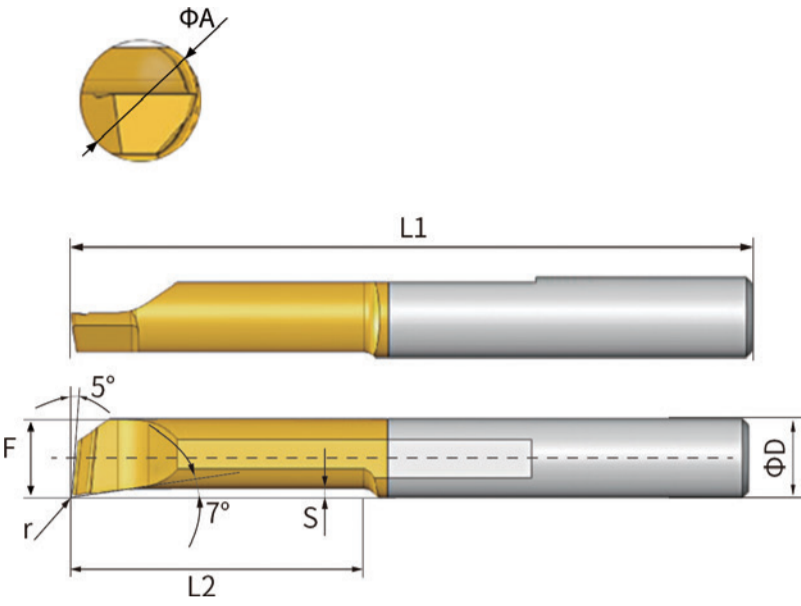

INTERNAL BORING

内孔镗刀

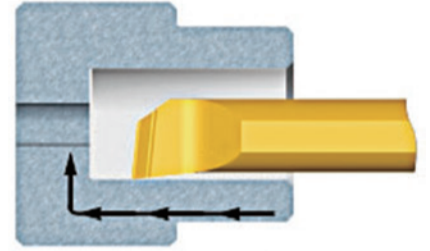

产品型号 Product Type	最小加工直径 Min.Dia (mm) ΦA	ΦD	r	L1	L2	F	S
MTR1.0R0.05L4	1.0	4	0.05	40	4	0.9	0.10
MTR1.5R0.05L5	1.5	4	0.05	40	5	1.4	0.15
MTR1.5R0.1L5	1.5	4	0.10	40	5	1.4	0.15
MTR1.5R0.05L8	1.5	4	0.05	40	8	1.4	0.15
MTR1.5R0.1L8	1.5	4	0.10	40	8	1.4	0.15
MTR2R0.05L6	2.1	4	0.05	40	6	1.85	0.20
MTR2R0.1L6	2.1	4	0.10	40	6	1.85	0.20
MTR2R0.05L10	2.1	4	0.05	40	10	1.85	0.20
MTR2R0.1L10	2.1	4	0.10	40	10	1.85	0.20
MTR2.5R0.05L8	2.6	4	0.05	40	8	2.35	0.25
MTR2.5R0.1L8	2.6	4	0.10	40	8	2.35	0.25
MTR2.5R0.15L8	2.6	4	0.15	40	8	2.35	0.25
MTR2.5R0.05L12	2.6	4	0.05	40	12	2.35	0.25
MTR2.5R0.1L12	2.6	4	0.10	40	12	2.35	0.25
MTR2.5R0.15L12	2.6	4	0.15	40	12	2.35	0.25
MTR3R0.05L10	3.1	4	0.05	40	10	2.8	0.30
MTR3R0.1L10	3.1	4	0.10	40	10	2.8	0.30
MTR3R0.15L10	3.1	4	0.15	40	10	2.8	0.30
MTR3R0.05L15	3.1	4	0.05	45	15	2.8	0.30
MTR3R0.1L15	3.1	4	0.10	45	15	2.8	0.30
MTR3R0.15L15	3.1	4	0.15	45	15	2.8	0.30
MTR3.5R0.15L15	3.6	4	0.15	45	15	3.3	0.35
MTR3.5R0.15L20	3.6	4	0.15	50	20	3.3	0.35
MTR4R0.05L12	4.1	4	0.05	45	12	3.8	0.40
MTR4R0.1L12	4.1	4	0.10	45	12	3.8	0.40
MTR4R0.2L12	4.1	4	0.20	45	12	3.8	0.40
MTR4R0.05L16	4.1	4	0.05	45	16	3.8	0.40
MTR4R0.1L16	4.1	4	0.10	45	16	3.8	0.40
MTR4R0.2L16	4.1	4	0.20	45	16	3.8	0.40
MTR4R0.05L20	4.1	4	0.05	50	20	3.8	0.40
MTR4R0.1L20	4.1	4	0.10	50	20	3.8	0.40
MTR4R0.2L20	4.1	4	0.20	50	20	3.8	0.40
MTR5R0.05L15	5.1	5	0.05	50	15	4.8	0.50
MTR5R0.1L15	5.1	5	0.10	50	15	4.8	0.50
MTR5R0.2L15	5.1	5	0.20	50	15	4.8	0.50
MTR5R0.05L20	5.1	5	0.05	54	20	4.8	0.50
MTR5R0.1L20	5.1	5	0.10	54	20	4.8	0.50
MTR5R0.2L20	5.1	5	0.20	54	20	4.8	0.50
MTR5R0.05L25	5.1	5	0.05	60	25	4.8	0.50
MTR5R0.1L25	5.1	5	0.10	60	25	4.8	0.50
MTR5R0.2L25	5.1	5	0.20	60	25	4.8	0.50
MTR5R0.2L35	5.1	5	0.20	70	35	4.8	0.50
MTR6R0.05L15	6.1	6	0.05	50	15	5.8	0.60
MTR6R0.1L15	6.1	6	0.10	50	15	5.8	0.60
MTR6R0.2L15	6.1	6	0.20	50	15	5.8	0.60
MTR6R0.05L22	6.1	6	0.05	60	22	5.8	0.60
MTR6R0.1L22	6.1	6	0.10	60	22	5.8	0.60
MTR6R0.2L22	6.1	6	0.20	60	22	5.8	0.60
MTR6R0.05L30	6.1	6	0.05	65	30	5.8	0.60
MTR6R0.1L30	6.1	6	0.10	65	30	5.8	0.60
MTR6R0.2L30	6.1	6	0.20	65	30	5.8	0.60
MTR6R0.2L35	6.1	6	0.20	70	35	5.8	0.60
MTR6R0.2L40	6.1	6	0.20	75	40	5.8	0.60
MTR7R0.1L25	7.1	7	0.10	65	25	6.8	0.70
MTR7R0.2L25	7.1	7	0.20	65	25	6.8	0.70
MTR7R0.1L30	7.1	7	0.10	65	30	6.8	0.70
MTR7R0.2L30	7.1	7	0.20	65	30	6.8	0.70
MTR7R0.2L35	7.1	7	0.20	70	35	6.8	0.70
MTR8R0.1L30	8.1	8	0.10	65	30	7.8	0.85
MTR8R0.2L30	8.1	8	0.20	65	30	7.8	0.85
MTR8R0.2L40	8.1	8	0.20	75	40	7.8	0.85

MPR

PROFILING AND BORING 仿形镗刀

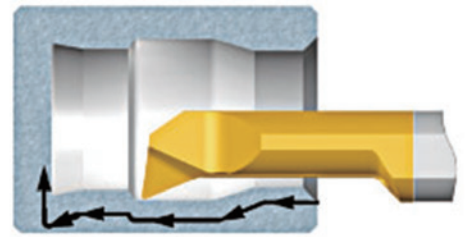
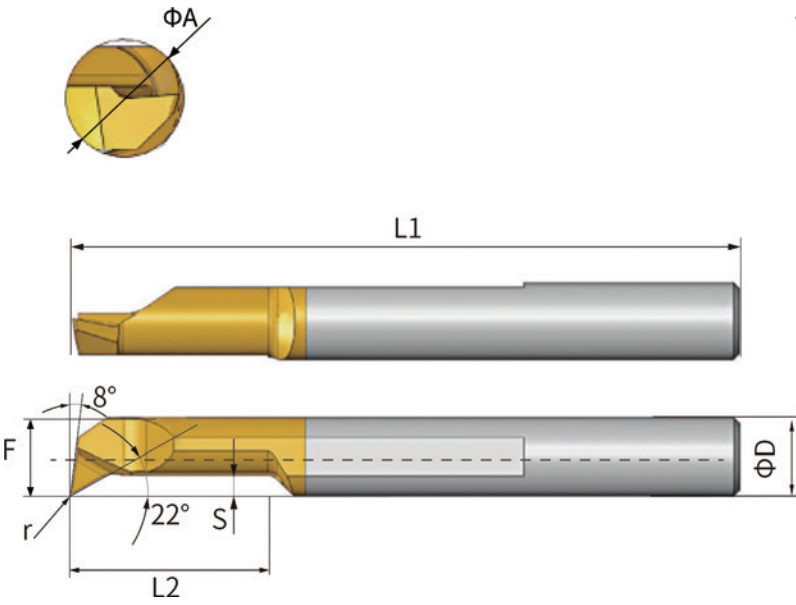

产品型号 Product Type	最小加工直径 Min.Dia (mm) ΦA	ΦD	r	L1	L2	F	S
MPR1.0R0.05L4	1.0	4	0.05	40	4	0.9	0.15
MPR1.2R0.05L4	1.2	4	0.05	40	4	1.1	0.15
MPR1.5R0.05L5	1.5	4	0.05	40	5	1.4	0.20
MPR1.5R0.1L5	1.5	4	0.10	40	5	1.4	0.20
MPR1.5R0.05L8	1.5	4	0.05	40	8	1.4	0.20
MPR1.5R0.1L8	1.5	4	0.10	40	8	1.4	0.20
MPR1.8R0.05L5	1.8	4	0.05	40	5	1.7	0.20
MPR1.8R0.1L5	1.8	4	0.10	40	5	1.7	0.20
MPR1.8R0.05L9	1.8	4	0.05	40	9	1.7	0.20
MPR1.8R0.1L9	1.8	4	0.10	40	9	1.7	0.20
MPR2R0.05L6	2.1	4	0.05	40	6	1.85	0.25
MPR2R0.1L6	2.1	4	0.10	40	6	1.85	0.25
MPR2R0.05L10	2.1	4	0.05	40	10	1.85	0.25
MPR2R0.1L10	2.1	4	0.10	40	10	1.85	0.25
MPR2.5R0.05L8	2.6	4	0.05	40	8	2.35	0.30
MPR2.5R0.1L8	2.6	4	0.10	40	8	2.35	0.30
MPR2.5R0.15L8	2.6	4	0.15	40	8	2.35	0.30
MPR2.5R0.05L12	2.6	4	0.05	40	12	2.35	0.30
MPR2.5R0.1L12	2.6	4	0.10	40	12	2.35	0.30
MPR2.5R0.15L12	2.6	4	0.15	40	12	2.35	0.30
MPR3R0.05L10	3.1	4	0.05	40	10	2.8	0.50
MPR3R0.1L10	3.1	4	0.10	40	10	2.8	0.50
MPR3R0.15L10	3.1	4	0.15	40	10	2.8	0.50
MPR3R0.05L15	3.1	4	0.05	45	15	2.8	0.50
MPR3R0.1L15	3.1	4	0.10	45	15	2.8	0.50
MPR3R0.15L15	3.1	4	0.15	45	15	2.8	0.50
MPR4R0.05L12	4.1	4	0.05	45	12	3.8	0.60
MPR4R0.1L12	4.1	4	0.10	45	12	3.8	0.60
MPR4R0.2L12	4.1	4	0.20	45	12	3.8	0.60
MPR4R0.05L16	4.1	4	0.05	45	16	3.8	0.60
MPR4R0.1L16	4.1	4	0.10	45	16	3.8	0.60
MPR4R0.2L16	4.1	4	0.20	45	16	3.8	0.60
MPR4R0.05L20	4.1	4	0.05	50	20	3.8	0.60
MPR4R0.1L20	4.1	4	0.10	50	20	3.8	0.60
MPR4R0.2L20	4.1	4	0.20	50	20	3.8	0.80
MPR5R0.05L15	5.1	5	0.05	50	15	4.8	0.80
MPR5R0.1L15	5.1	5	0.10	50	15	4.8	0.80
MPR5R0.2L15	5.1	5	0.20	50	15	4.8	0.80
MPR5R0.05L20	5.1	5	0.05	54	20	4.8	0.80
MPR5R0.1L20	5.1	5	0.10	54	20	4.8	0.80
MPR5R0.2L20	5.1	5	0.20	54	20	4.8	0.80
MPR5R0.05L25	5.1	5	0.05	60	25	4.8	0.80
MPR5R0.1L25	5.1	5	0.10	60	25	4.8	0.80
MPR5R0.2L25	5.1	5	0.20	60	25	4.8	0.80
MPR6R0.05L15	6.1	6	0.05	50	15	5.8	1.00
MPR6R0.1L15	6.1	6	0.10	50	15	5.8	1.00
MPR6R0.2L15	6.1	6	0.20	50	15	5.8	1.00
MPR6R0.05L22	6.1	6	0.05	60	22	5.8	1.00
MPR6R0.1L22	6.1	6	0.10	60	22	5.8	1.00
MPR6R0.2L22	6.1	6	0.20	60	22	5.8	1.00
MPR6R0.05L30	6.1	6	0.05	65	30	5.8	1.00
MPR6R0.1L30	6.1	6	0.10	65	30	5.8	1.00
MPR6R0.2L30	6.1	6	0.20	65	30	5.8	1.00
MPR7R0.1L25	7.1	7	0.10	65	25	6.8	1.20
MPR7R0.2L25	7.1	7	0.20	65	25	6.8	1.20
MPR7R0.1L30	7.1	7	0.10	70	30	6.8	1.20
MPR7R0.2L30	7.1	7	0.20	70	30	6.8	1.20
MPR8R0.1L30	8.1	8	0.10	65	30	7.8	1.50
MPR8R0.2L30	8.1	8	0.20	65	30	7.8	1.50
MPR8R0.2L40	8.1	8	0.20	75	40	7.8	1.50

MUR

PROFILING, 90° FACE CUTTING 仿形平底镗刀

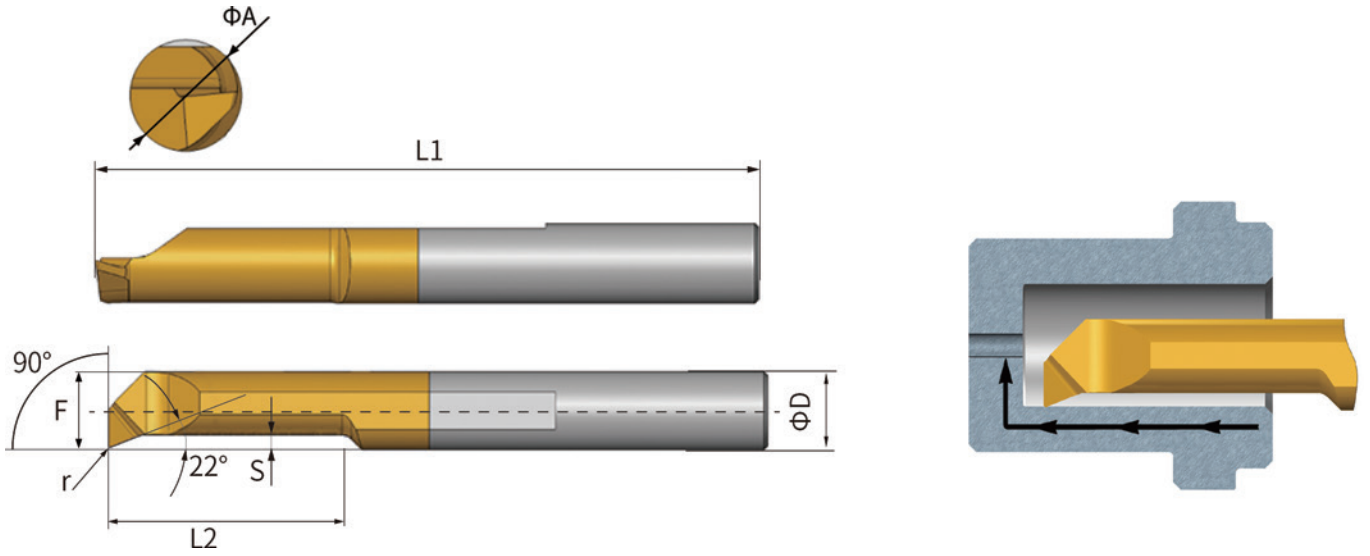

产品型号 Product Type	最小加工直径 Min.Dia (mm) ΦA	ΦD	r	L1	L2	F	S
MUR3R0.1L10	3.1	4	0.10	40	10	2.8	0.40
MUR4R0.1L12	4.1	4	0.10	46	12	3.8	0.50
MUR5R0.15L15	5.1	5	0.15	50	15	4.8	0.70
MUR6R0.15L22	6.1	6	0.15	60	22	5.8	0.90

MQR

INTERNAL PROFILING AND BORING 内孔仿形镗刀

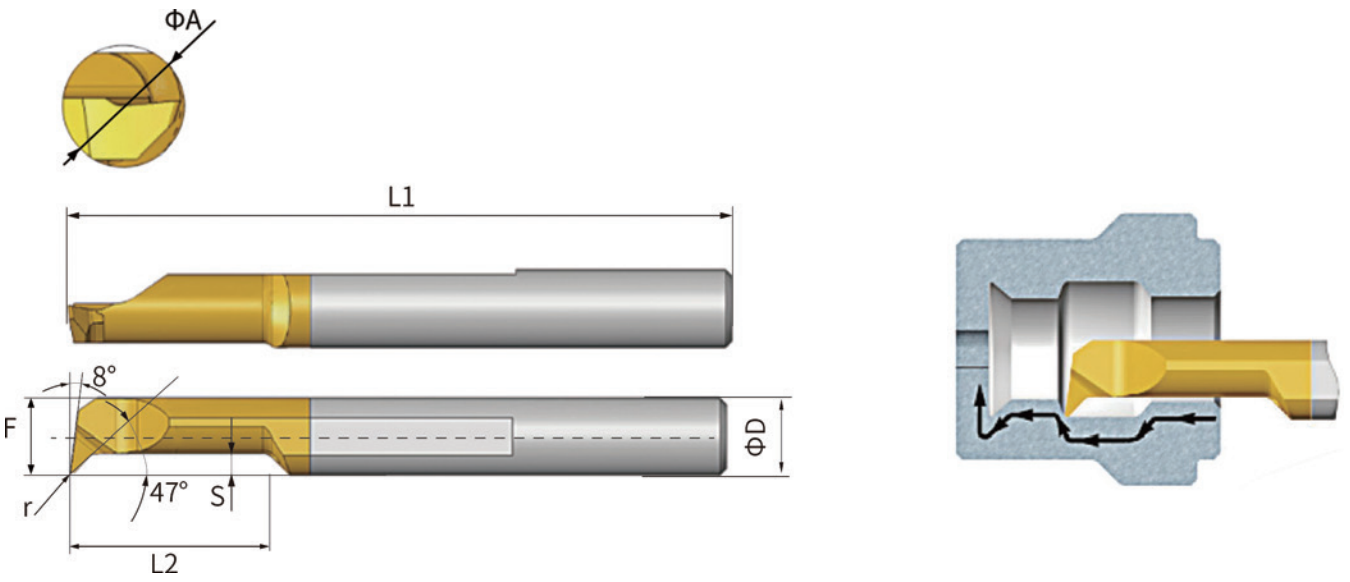

产品型号 Product Type	最小加工直径 Min.Dia (mm) ΦA	ΦD	r	L1	L2	F	S
MQR3R0.1L10	3.1	4	0.10	40	10	2.8	0.60
MQR3R0.1L15	3.1	4	0.10	46	15	2.8	0.60
MQR4R0.1L12	4.1	4	0.10	46	12	3.8	0.80
MQR4R0.1L20	4.1	4	0.10	50	20	3.8	0.80
MQR5R0.15L15	5.1	5	0.15	50	15	4.8	1.00
MQR5R0.15L25	5.1	5	0.15	60	25	4.8	1.00
MQR6R0.15L20	6.1	6	0.15	50	20	5.8	1.20
MQR6R0.15L30	6.1	6	0.15	60	30	5.8	1.20
MQR8R0.2L22	8.1	8	0.20	60	22	7.8	1.50
MQR8R0.2L30	8.1	8	0.20	65	30	7.8	1.50

MIR

INTERNAL THREADING 内孔泛用螺纹镗刀

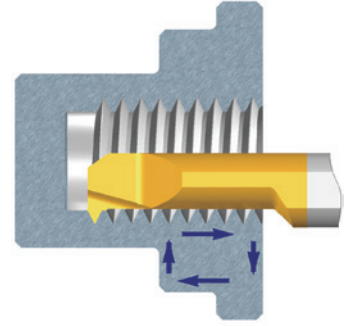
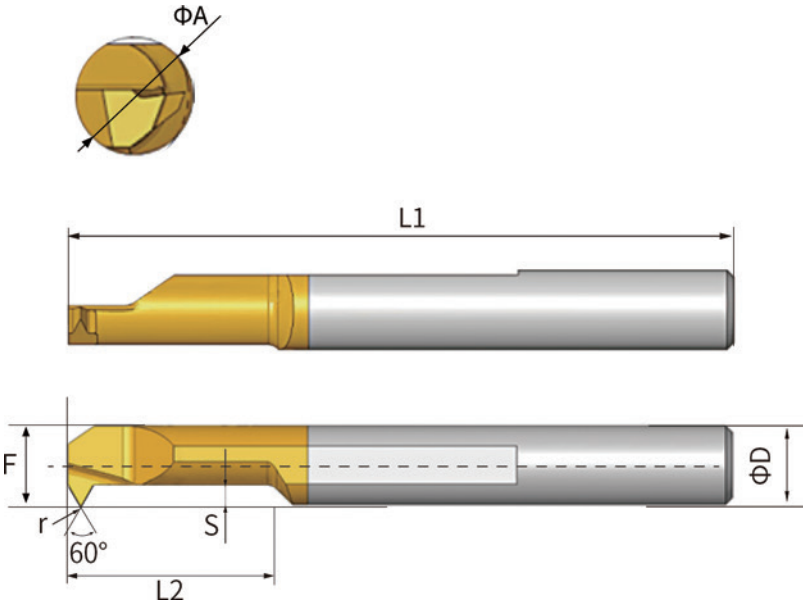

60°范围牙

产品型号 Product Type	最小加工直径 Min.Dia (mm) ΦA	ΦD	r	L1	L2	F	S	Pitch Range 螺距范围
MIR1.5L4A60	1.5	4	0.03	40	4	1.4	0.40	0.25~0.4
MIR2.0L6A60	2	4	0.03	40	6	1.9	0.50	0.25~0.5
MIR2.5L8A60	2.5	4	0.05	40	8	2.4	0.60	0.25~0.6
MIR3L10A60	3	4	0.05	40	10	2.9	1.00	0.4~0.8
MIR4L12A60X	4	4	0.05	46	12	3.9	1.20	0.4~1.0
MIR4L12A60	4	4	0.10	46	12	3.9	1.20	0.8~1.0
MIR5L15A60X	5	5	0.05	50	15	4.9	1.50	0.4~1.5
MIR5L15A60	5	5	0.10	50	15	4.9	1.50	0.8~1.5
MIR6L20A60X	6	6	0.05	60	20	5.9	1.80	0.4~1.75
MIR6L20A60	6	6	0.10	60	20	5.9	1.80	0.8~1.75
MIR8L25A60	8	8	0.10	65	25	7.9	2.20	0.8~2.0
MIR8L30A60	8	8	0.10	65	30	7.9	2.20	0.8~2.0

MIR

INTERNAL THREADING 内孔泛用螺纹镗刀

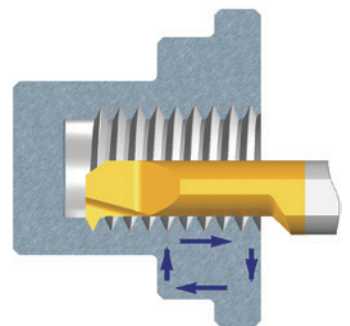
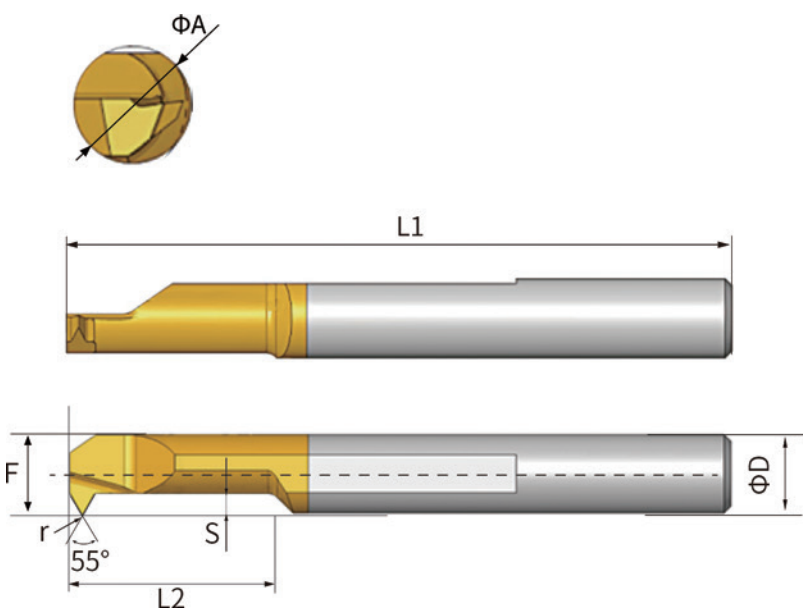

55°范围牙

产品型号 Product Type	最小加工直径 Min.Dia (mm) ΦA	ΦD	r	L1	L2	F	S	Pitch Range 螺距范围
MIR3L10A55	3.1	4	0.05	40	10	2.9	1.00	48-24
MIR4L12A55	4.1	4	0.05	46	12	3.9	1.20	48-24
MIR5L15A55	5.1	5	0.08	50	15	4.9	1.60	48-16
MIR6L20A55	6.1	6	0.08	60	20	5.9	1.90	48-12
MIR8L25A55	8.1	8	0.15	65	25	7.9	2.50	26-11
MIR8L30A55	8.1	8	0.15	65	30	7.9	2.50	26-11

MGR

INTERNAL GROOVING

内孔切槽刀

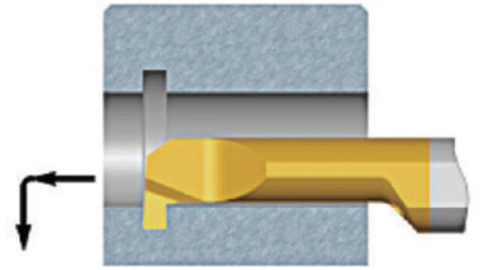
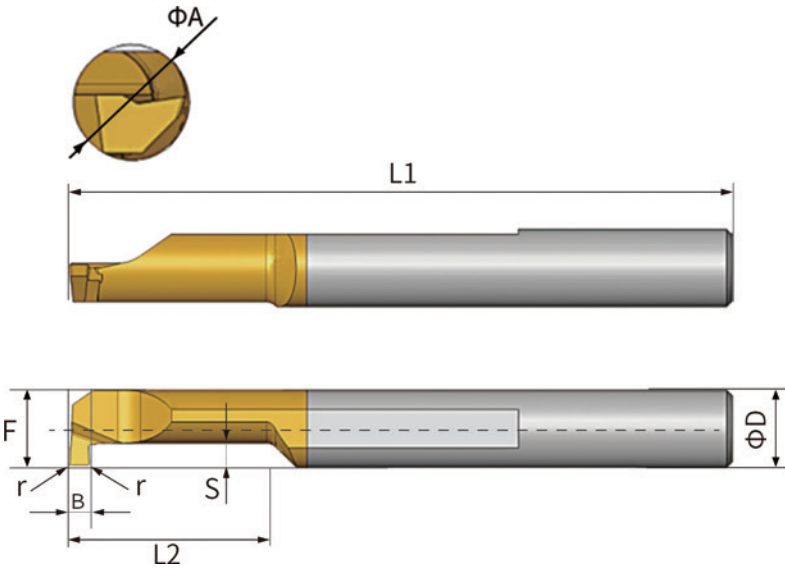

产品型号 Product Type	最小加工直径 Min.Dia (mm) ΦA	ΦD	r	L1	L2	F	S	B
MGR2.5B0.5L5	2.5	4	0.05	40	5	2.35	0.65	0.50
MGR2.5B0.75L5	2.5	4	0.05	40	5	2.35	0.65	0.75
MGR3B0.5L5	3.0	4	0.05	40	5	2.8	0.80	0.50
MGR3B0.75L5	3.0	4	0.05	40	5	2.8	0.80	0.75
MGR3B1.0L5	3.0	4	0.05	40	5	2.8	0.80	1.00
MGR3B0.5L10	3.0	4	0.05	40	10	2.8	0.80	0.50
MGR3B0.75L10	3.0	4	0.05	40	10	2.8	0.80	0.75
MGR3B1.0L10	3.0	4	0.05	40	10	2.8	0.80	1.00
MGR4B0.5L6	4.0	4	0.05	40	6	3.8	1.00	0.50
MGR4B0.75L6	4.0	4	0.05	40	6	3.8	1.00	0.75
MGR4B1.0L6	4.0	4	0.05	40	6	3.8	1.00	1.00
MGR4B1.5L6	4.0	4	0.05	40	6	3.8	1.00	1.50
MGR4B0.5L12	4.0	4	0.05	46	12	3.8	1.00	0.50
MGR4B0.75L12	4.0	4	0.05	46	12	3.8	1.00	0.75
MGR4B1.0L12	4.0	4	0.05	46	12	3.8	1.00	1.00
MGR4B1.5L12	4.0	4	0.05	46	12	3.8	1.00	1.50
MGR5B1.0L8	5.0	5	0.10	45	8	4.8	1.50	1.00
MGR5B1.5L8	5.0	5	0.10	45	8	4.8	1.50	1.50
MGR5B2.0L8	5.0	5	0.10	45	8	4.8	1.50	2.00
MGR5B1.0L15	5.0	5	0.10	50	15	4.8	1.50	1.00
MGR5B1.5L15	5.0	5	0.10	50	15	4.8	1.50	1.50
MGR5B2.0L15	5.0	5	0.10	50	15	4.8	1.50	2.00
MGR6B1.0L10	6.0	6	0.10	50	10	5.8	2.00	1.00
MGR6B1.5L10	6.0	6	0.10	50	10	5.8	2.00	1.50
MGR6B2.0L10	6.0	6	0.10	50	10	5.8	2.00	2.00
MGR6B1.0L20	6.0	6	0.10	60	20	5.8	2.00	1.00
MGR6B1.5L20	6.0	6	0.10	60	20	5.8	2.00	1.50
MGR6B2.0L20	6.0	6	0.10	60	20	5.8	2.00	2.00
MGR7B1.0L22	7.0	7	0.10	62	22	6.8	2.00	1.00
MGR7B1.5L22	7.0	7	0.10	62	22	6.8	2.50	1.50
MGR7B2.0L22	7.0	7	0.10	62	22	6.8	2.50	2.00
MGR8B1.0L22	8.0	8	0.10	64	22	7.8	1.80	1.00
MGR8B1.5L25	8.0	8	0.10	65	25	7.8	2.50	1.50
MGR8B2.0L25	8.0	8	0.10	65	25	7.8	2.50	2.00
MGR8B2.5L25	8.0	8	0.10	65	25	7.8	2.50	2.50

MXR

REVERSE BORING CUTTER

反向镗刀

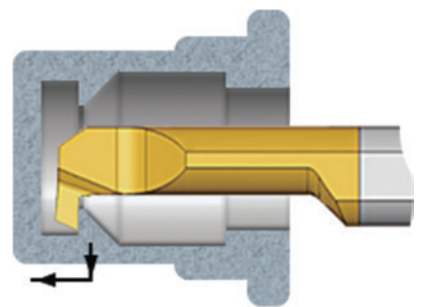
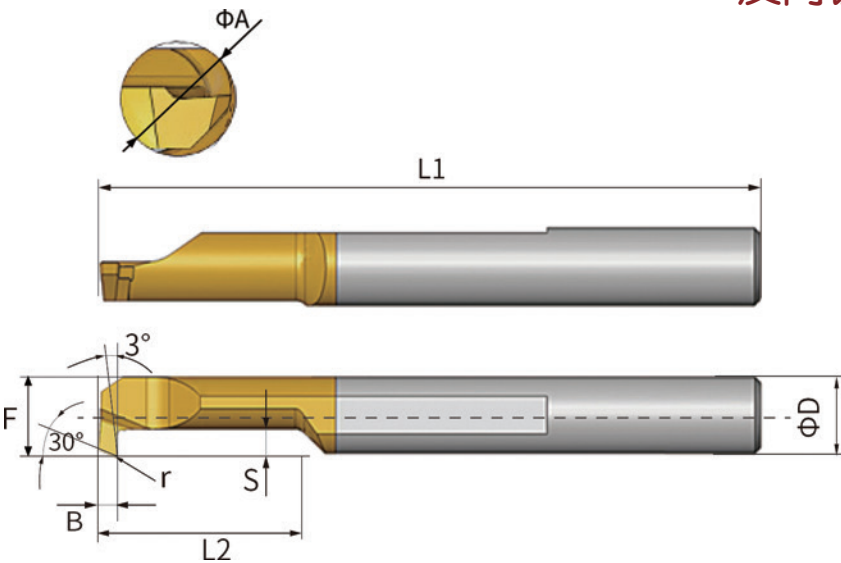

产品型号 Product Type	最小加工直径 Min.Dia (mm) ΦA	ΦD	r	L1	L2	F	S	B
MXR4R0.1L16	4.1	4	0.10	46	16	3.8	1.00	1.3
MXR5R0.1L20	5.1	5	0.10	54	20	4.8	1.30	1.5
MXR6R0.1L25	6.1	6	0.10	60	25	5.8	1.60	1.5

MFR

FACE GROOVING 端面槽刀

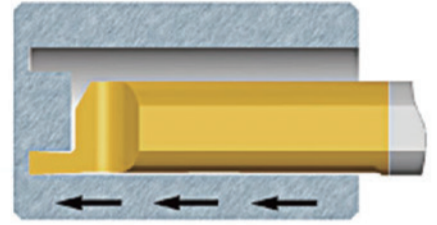
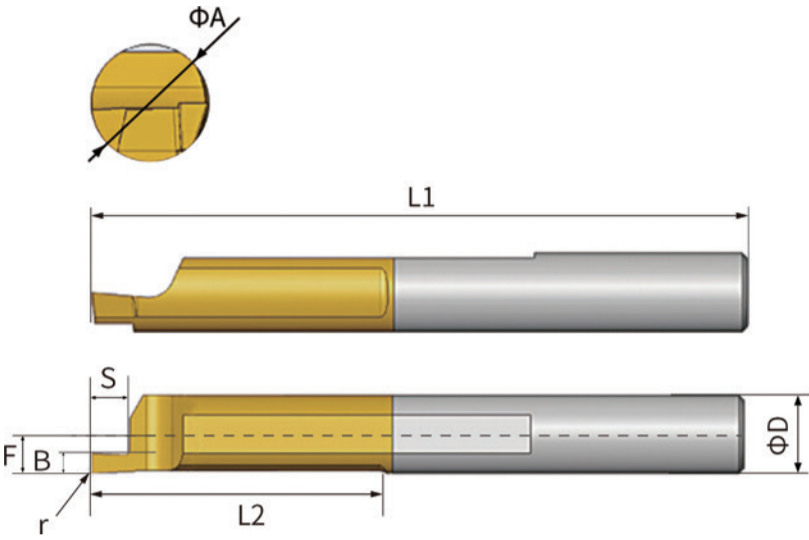

产品型号 Product Type	最小加工直径 Min.Dia (mm) ΦA	ΦD	r	L1	L2	F	S	B
MFR4B0.5L12	5	4	0.05	40	12	1.9	1.0	0.50
MFR4B1.0L12	5	4	0.05	40	12	1.9	1.5	1.00
MFR4B1.5L12	5	4	0.05	40	12	1.9	2.0	1.50
MFR5B1.0L15	6	5	0.10	50	15	2.4	1.5	1.00
MFR5B1.5L15	6	5	0.10	50	15	2.4	2.5	1.50
MFR5B2.0L15	6	5	0.10	50	15	2.4	3.0	2.00
MFR6B1.0L20	8	6	0.10	50	20	2.9	2.0	1.00
MFR6B1.5L20	8	6	0.10	50	20	2.9	2.5	1.50
MFR6B2.0L20	8	6	0.10	50	20	2.9	3.0	2.00
MFR6B3.0L20	8	6	0.10	50	20	2.9	4.5	3.00
MFR8B2.5L22	10	8	0.10	60	22	3.9	3.5	2.50

MVR

DEEP FACE GROOVING 深端面槽刀

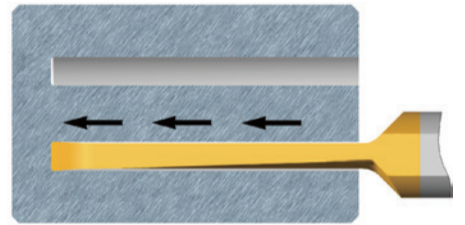
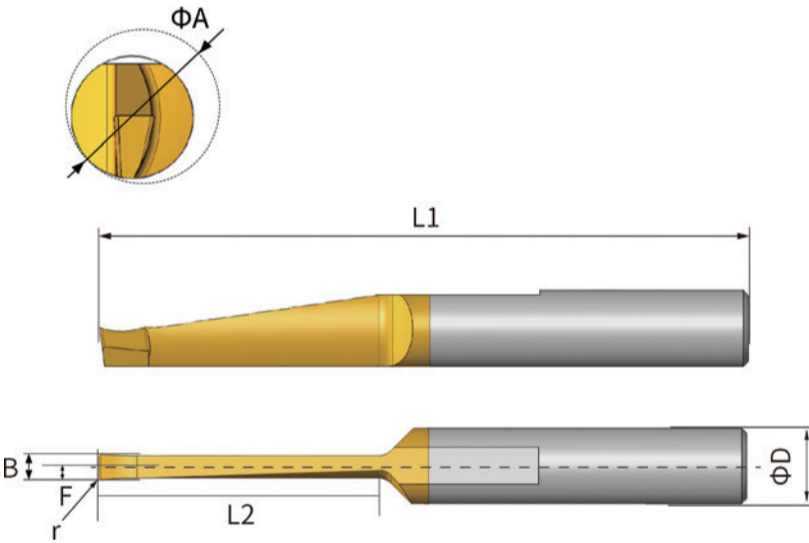

产品型号 Product Type	最小加工直径 Min.Dia (mm) ΦA	ΦD	r	L1	L2	B	F
MVR8B2.0L15	12	8	0.2	60	15	2.0	1.1
MVR8B2.5L15	12	8	0.2	60	15	2.5	1.4
MVR8B3.0L15	12	8	0.2	60	15	3.0	1.6

TINY TOOLS TOOLHOLDER

微型小镗刀变径套刀杆

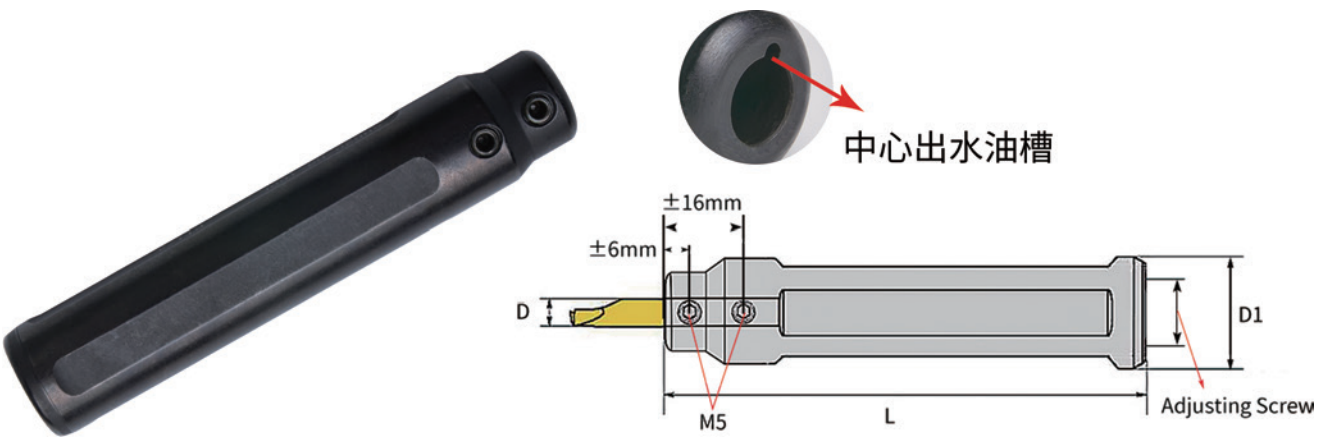

产品型号 Product Type	D	D1	L	内冷接口螺纹 Adjusting Screw
SHB16-D4-L100	16	4	100	PT1/8
SHB16-D5-L100	16	5	100	PT1/8
SHB16-D6-L100	16	6	100	PT1/8
SHB16-D7-L100	16	7	100	PT1/8
SHB16-D8-L100	16	8	100	PT1/8
SHB20-D4-L100	20	4	100	PT1/4
SHB20-D5-L100	20	5	100	PT1/4
SHB20-D6-L100	20	6	100	PT1/4
SHB20-D7-L100	20	7	100	PT1/4
SHB20-D8-L100	20	8	100	PT1/4
SHB22-D4-L100	22	4	100	PT1/4
SHB22-D5-L100	22	5	100	PT1/4
SHB22-D6-L100	22	6	100	PT1/4
SHB22-D7-L100	22	7	100	PT1/4
SHB22-D8-L100	22	8	100	PT1/4
SHB25-D4-L100	25	4	100	PT3/8
SHB25-D5-L100	25	5	100	PT3/8
SHB25-D6-L100	25	6	100	PT3/8
SHB25-D7-L100	25	7	100	PT3/8
SHB25-D8-L100	25	8	100	PT3/8
SHB25.4-D4-L100	25.4	4	100	PT3/8
SHB25.4-D5-L100	25.4	5	100	PT3/8
SHB25.4-D6-L100	25.4	6	100	PT3/8
SHB25.4-D7-L100	25.4	7	100	PT3/8
SHB25.4-D8-L100	25.4	8	100	PT3/8

COATING ITEM

涂层说明

Coated Item 涂层编号	Color 颜色	Application 加工材料	Performance parameter 特性参数
AT12	Gold 金色 	Universal use for ≤HRC45 material; Stainless(austenitic&Martensite,303,304,316F...); Steel(Bearing steel, quenched steel, Cr-Mo steel, Mn steel...); Koveralloy; Superalloy;Copper; Iron casting;Pig iron; Nickel alloy,PMMA... 泛用于HRC45以内材料, 包括但不限于: 奥氏体/马氏体不锈钢,303,316F,镍不锈钢等; 钢材(淬火钢, 洛钼钢, 锰钢等碳钢); 生铁, 铸铁, 镍合金, 亚克力等。	Complex coating;durable and lubricious
JS25	Bronze 古铜色 	Universal use for ≤HRC60 material; Stainless(austenitic&Martensite,316L,303,304,321,316F,High Nickel Stainless...); Steel(Bearing steel,quenched steel,Cr-Mo steel,Mn steel...); Koveralloy; Superalloy;Copper; Iron casting;Pig iron; Nickel alloy.. 泛用于HRC60以内材料, 包括但不限于: 奥氏体/马氏体不锈钢,316L,303,321,316F,高镍不锈钢等; 钢材(轴承钢, 淬火钢, 洛钼钢, 锰钢等高碳钢); 可伐合金; 高温合金; 生铁, 铸铁, 镍合金等。	Durable, High temperature resistance≤1100°C High hardness 3300Hiv0.05 耐高温耐磨高硬度 1100°C; 3300Hiv0.05
AL25	Black Blue 黑蓝色 	Special use for mild material ; Especial for Pure iron , special for mild steel & mild stainless,like 304. 特别用于低碳材料, 尤其纯铁; 适用于低碳钢和低碳不锈钢, 比如304不锈钢	Lubricious 润滑
LC25	Black /Rainbow 黑色/七彩色 	Special use for viscous Material;; Aluminium, PMMA, Polyethylene.CFRP. 粘材专用, 尤其铝材、亚克力、聚乙烯, 碳纤维材料。	Minimum friction coefficient 0.1-0.2 极小摩擦系数0.1-0.2
AT25	Champagne Gold 香槟金色 	Special use for titanium alloy. 钛合金专用。	Special for titanium alloy
NC25	None coated 无涂层 	Nonferrous Metals include Aluminium 适用于有色金属包括铝材, 非专用	